

REVISIONS				
REV.	ECN	REVISION DESCRIPTION	CHKD	DATE
A	-	INITIAL RELEASE		11-Aug-21

NOTE:
1. BOM ITEM NO.11, NO.12 AND NO.13 ARE NOT SHOWN ON DRAWING.

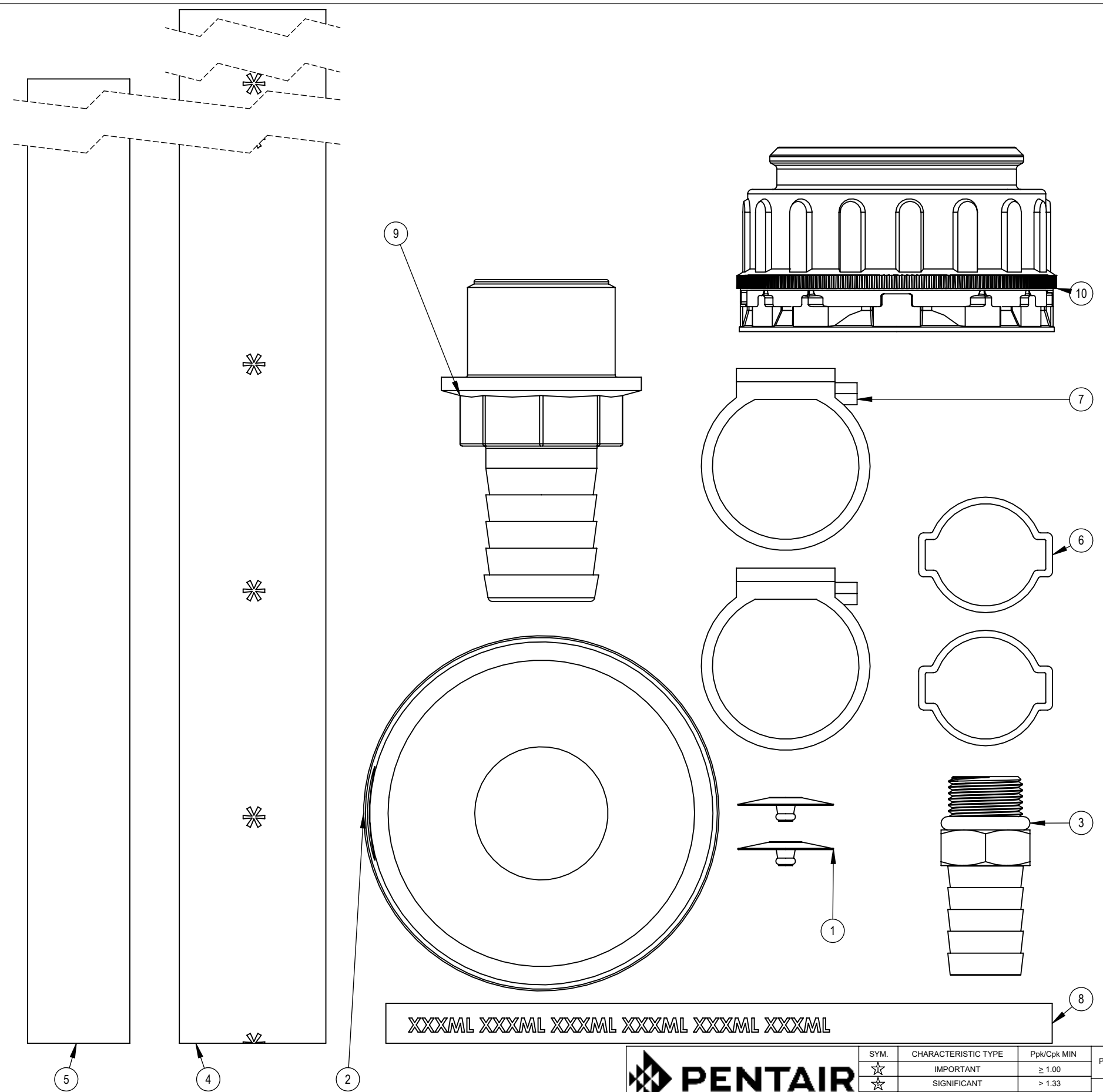

ITEM NO.	PART NUMBER	DESCRIPTION	QTY.
1	PNRNEX-KITUMB	CTS UMBRELLA VALVE KIT	1
2	2420-0028	MOUNTING BOSS CTS	1
3	2420-0048	ADAPTOR BSPP38 X HB17 BRASS	1
4	2900-0111	HOSE METERING CTS	1
5	2900-0112	HOSE RINSE WATER CTS	1
6	2910-0039	HOSE CLAMP 78 MS PLATED	2
7	2910-0040	CLAMP HOSE 25MM	2
8	6030-0008	LABEL METERING HOSE CTS	1
9	2404-0479	CTS SUCTION HOSE BARB	1
10	EC-CAP01	EASYCONNECT CAP	1
11	PNR-CN100-OIPM	CTS MANUAL	1
12	XXXXXXX	STORAGE BAG	1
13	XXXXXXX	BAG LABEL	1

XXXXML XXXML XXXML XXXML XXXML XXXML

PENTAIR HYPRO
 375 Fifth Avenue NW
 New Brighton, MN 55112
 (651) 766-6300

SYM.	CHARACTERISTIC TYPE	Ppk/Cpk MIN
☆	IMPORTANT	≥ 1.00
☆	SIGNIFICANT	> 1.33
☆	CRITICAL	> 1.67

DWG BY: CB	DATE: 11-AUG-21
CHECKED BY:	DATE:
APPROVED BY:	DATE:

SIZE: B	SCALE: 1:50	DO NOT SCALE PRINT	SHEET NO. 1 OF 1
---------	-------------	--------------------	------------------

THIS DRAWING IS THE CONFIDENTIAL PROPERTY OF PENTAIR LTD. AND WITHOUT WRITTEN AUTHORIZATION, MUST NOT BE COPIED OR COMMUNICATED

UNLESS OTHERWISE SPECIFIED ALL DIMENSIONS ARE IN MM

TOLERANCES (+ OR -)
 ANGLE: 0.5°

SURFACE FINISH
 3.2 Ra MAX

DECIMAL .X: .2
 DECIMAL .XX: .10
 DECIMAL .XXX: .050

PART VOLUME mm³	PART WEIGHT g
SURFACE TREATMENT	
HEAT TREATMENT	
MATERIAL	

DRAWING BASED ON ASME Y14.5M-1994

THIRD ANGLE PROJECTION

PART DESCRIPTION
 CTS INSTALLATION KIT

PART NUMBER PNRNEX-KITINS	REV.
------------------------------	------