

REVISIONS				
REV.	ECN	REVISION DESCRIPTION	CHKD	DATE

NOTE:

1. BOM ITEM NO. 12 AND 13 ARE NOT SHOWN ON DRAWING

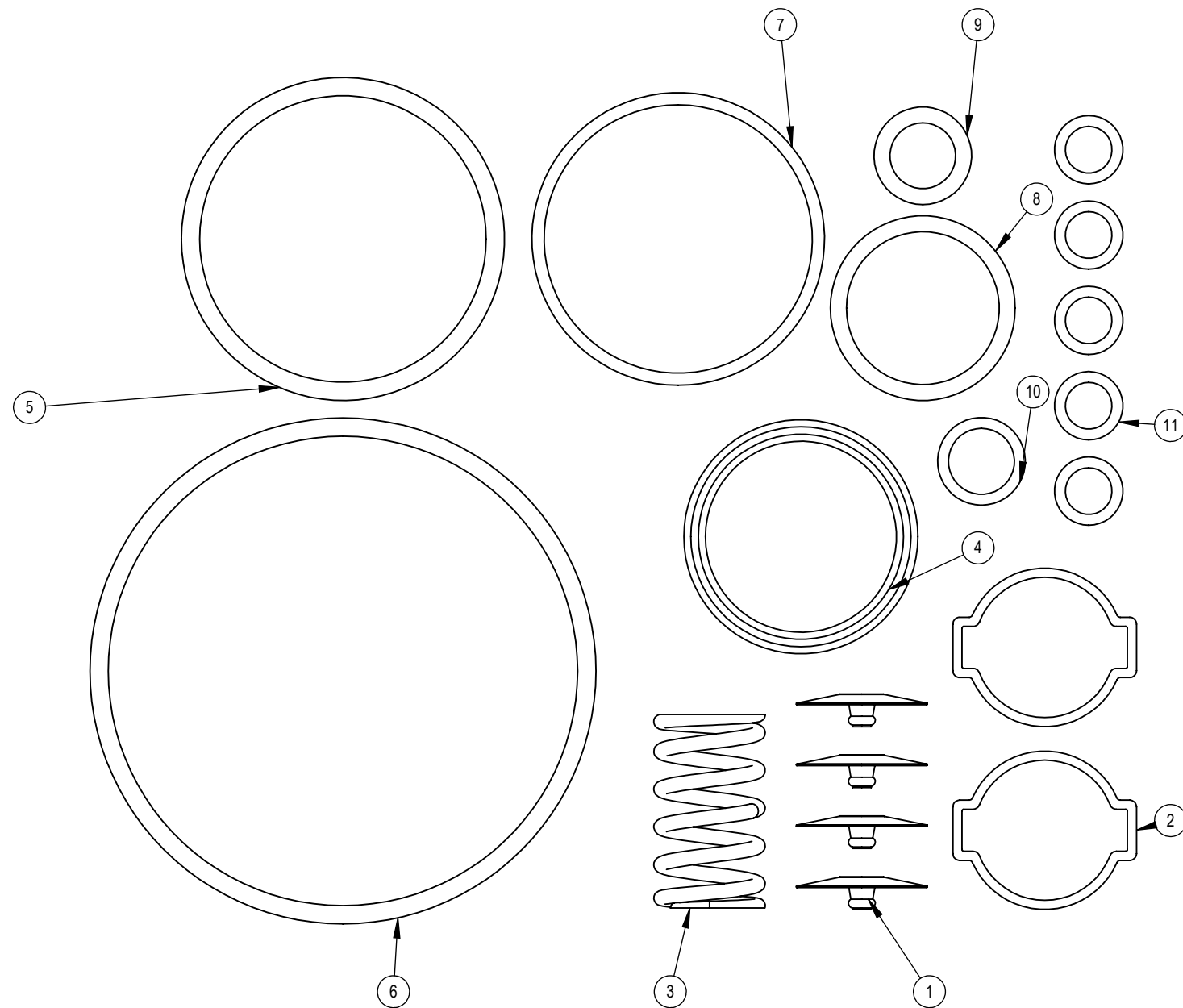

BOM Table			
ITEM NO.	PART NUMBER	DESCRIPTION	QTY.
1	PNRNEX-KITUMB	CTS UMBRELLA VALVE KIT	2
2	2910-0039	HOSE CLAMP 78 MS PLATED	2
3	2420-0059	SPRING COMPRESSION VALVE	1
4	1750-0001	QUAD RING 31.34X3.53MM VITON	1
5	1721-0252	O-RING 47X3MM VITON	1
6	1721-0253	O-RING 77X3MM VITON	1
7	1721-0266	O-RING 44X2MM VITON	1
8	1721-0267	O-RING 2.62x25.07 VITON	1
9	1721-0268	O-RING 10.78X2.62 VITON	1
10	1721-0269	O-RING 10.82X1.78 VITON	1
11	1721-0270	O-RING 7.65X1.78 VITON	5
12	XXXX	STORAGE BAG	1
13	XXXX	BAG LABEL	1

PENTAIR
HYPRO
375 Fifth Avenue NW
New Brighton, MN 55112
(651) 766-6300

SYM.	CHARACTERISTIC TYPE	Ppk/Cpk MIN
☆	IMPORTANT	≥ 1.00
☆	SIGNIFICANT	> 1.33
☆	CRITICAL	> 1.67
DWG BY:	DATE:	
CHECKED BY:	DATE:	
APPROVED BY:	DATE:	
SIZE	SCALE	SHEET NO.
B	1:1	1 OF 1

THIS DRAWING IS THE CONFIDENTIAL PROPERTY OF PENTAIR LTD. AND WITHOUT WRITTEN AUTHORIZATION, MUST NOT BE COPIED OR COMMUNICATED

UNLESS OTHERWISE SPECIFIED ALL DIMENSIONS ARE IN MM

TOLERANCES (+ OR -)
ANGLE: 0.5°

SURFACE FINISH
3.2 Ra MAX

DECIMAL .X: .2
DECIMAL .XX: .10
DECIMAL .XXX: .050

PART VOLUME	PART WEIGHT
mm ³	g
SURFACE TREATMENT	HEAT TREATMENT
MATERIAL	SEE BOM

DRAWING BASED ON ASME Y14.5M-1994

THIRD ANGLE PROJECTION

PART DESCRIPTION
CTS SERVICE KIT

PART NUMBER
PNRNEX-KITINS

REV.